

WALTHER FLENDER TAPERBUCHSEN

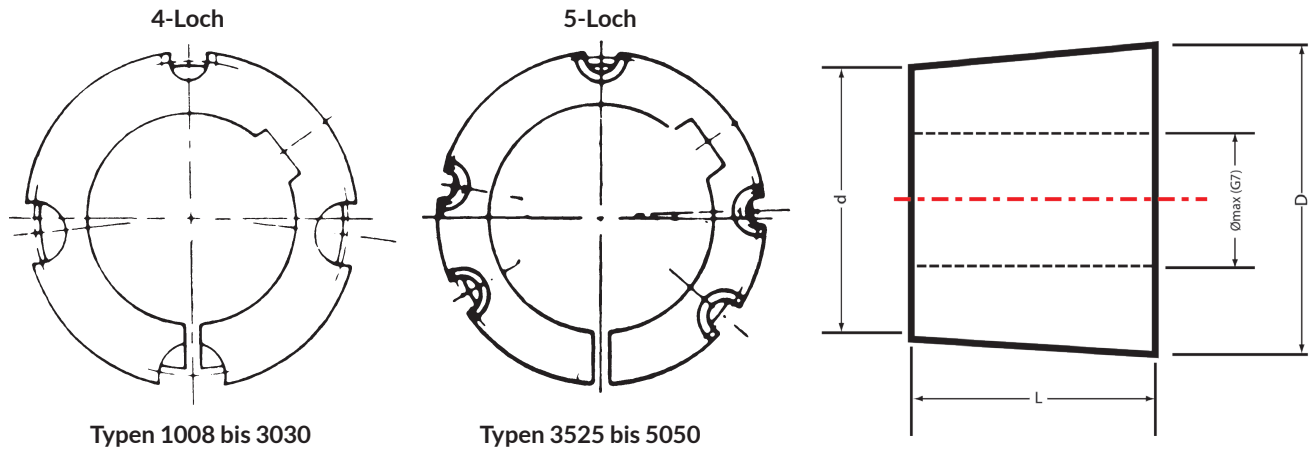

Verfügbare Größen

Type	Buchsenbohrung (mm)	Passfedernut (mm)		Buchse			Nabe min. Ø		Befestigung d x l x sw BSW x mm		
		breit	tief	max. Bohrungs-Ø	L	D	d	GG		ST	
1008	10	3	1,4	25	20,3	35,20	32	55	49	2 Gewindestifte	$\frac{1}{4} \cdot \frac{1}{2} \cdot 3$
	11 12	4	1,8								
	14 16	5	2,3								
	18 19 20 22	6	2,8								
	24 25	8	1,3*								
1108	10	3	1,4	28	20,3	38,38	36	60	52		$\frac{1}{4} \cdot \frac{1}{2} \cdot 3$
	11 12	4	1,8								
	14 16	5	2,3								
	18 19 20 22	6	2,8								
	24 25	8	3,3								
1210	11 12	4	1,8	32	25,4	47,62	44	80	73	$\frac{3}{8} \cdot \frac{5}{8} \cdot 5$	
	14 16	5	2,3								
	18 19 20 22	6	2,8								
	24 25 28 30	8	3,3								
	32	10	3,3								
1215	14 15 16	5	2,3	32	38,1	47,62	42	73	67	$\frac{3}{8} \cdot \frac{5}{8} \cdot 5$	
	18 19 20 22	6	2,8								
	24 25 28 30	8	3,3								
	32	10	2,4*								
	1310	14 15 16	5								2,3
18 19 20 22		6	2,8								
24 25 28 30		8	3,3								
32 35 38		10	3,3								
40 42		12	3,3								
1610	14 16	5	2,3	42	38,1	57,15	52	82	76	$\frac{3}{8} \cdot \frac{5}{8} \cdot 5$	
	18 19 20 22	6	2,8								
	24 25 28 30	8	3,3								
	32 35 38	10	3,3								
	40 42	12	1,3*								
2012	14 16	5	2,3	50	30,5	69,85	66	110	98	$\frac{7}{16} \cdot \frac{7}{8} \cdot 6$	
	18 19 20 22	6	2,8								
	24 25 28 30	8	3,3								
	32 35 38	10	3,3								
	40 42	12	3,3								
2517	16	5	2,3	65	43,2	85,73	80	125	111	$\frac{1}{2} \cdot 1 \cdot 6$	
	18 19 20 22	6	2,8								
	24 25 28 30	8	3,3								
	32 35 38	10	3,3								
	40 42	12	3,3								
	45 48 50	14	3,8								
	55	16	4,3								
60 65	18	4,4									
3020	25 28 30	8	3,3	75	50,8	107,95	101	155	143	$\frac{5}{8} \cdot 1 \frac{1}{4} \cdot 8$	
	32 35 38	10	3,3								
	40 42	12	3,3								
	45 48 50	14	3,8								
	55	16	4,3								
	60 65	18	4,3								
	70 75	20	4,9								

TECHNISCHES PRODUKTDATENBLATT

Type	Buchsenbohrung (mm)	Passfedernut (mm)		Buchse				Nabe min. Ø		Befestigung d x l x sw BSW x mm		
		breit	tief	max. Bohrungs- Ø	L	D	d	GG	ST			
3030	35 38	10	3,3	75	76,2	107,95	97	146	137	3 Schrauben	$\frac{5}{8} \cdot 1 \frac{1}{4} \cdot 8$	
	40 42	12	3,3									
	45 48 50	14	3,8									
	55	16	4,3									
	60 65	18	4,4									
70 75	20	4,9										
3525	35 38	10	3,3	100	63,5	127,00	118	178	165		3 Schrauben	$\frac{1}{2} \cdot 1 \frac{1}{2} \cdot 10$
	40 42	12	3,3									
	45 48 50	14	3,8									
	55	16	4,3									
	60 65	18	4,4									
	70 75	20	4,9									
	80 85	22	5,4									
90 95	25	5,4										
100	28	4,4*										
3535	35 38	10	3,3	90	89	127,00	115	178	165	3 Schrauben		$\frac{1}{2} \cdot 1 \frac{1}{2} \cdot 10$
	40 42	12	3,3									
	45 48 50	14	3,8									
	55	16	4,3									
	60 65	18	4,4									
	70 75	20	4,9									
4030	40 42	12	3,3	115	76,2	146,05	135	215	197		3 Schrauben	$\frac{5}{8} \cdot 1 \frac{3}{4} \cdot 12$
	45 48 50	14	3,8									
	55	16	4,3									
	60 65	18	4,4									
	70 75	20	4,9									
	80 85	22	5,4									
	90 95	25	5,4									
100 105 110	28	6,4										
115	32	5,4*										
4040	40 42	12	3,3	100	101	146,05	132	215	197	3 Schrauben		$\frac{5}{8} \cdot 1 \frac{3}{4} \cdot 12$
	45 48 50	14	3,8									
	55	16	4,3									
	60 65	18	4,4									
	70 75	20	4,9									
	80 85	22	5,4									
4535	55	16	4,3	125	89	161,93	150	240	222		3 Schrauben	$\frac{3}{4} \cdot 2 \cdot 14$
	60 65	18	4,4									
	70 75	20	4,9									
	80 85	22	5,4									
	90 95	25	5,4									
	100 105 110	28	6,4									
4545	55	16	4,3	110	114	161,93	146	240	222	3 Schrauben		$\frac{3}{4} \cdot 2 \cdot 14$
	60 65	18	4,4									
	70 75	20	4,9									
	80 85	22	5,4									
	90 95	25	5,4									
100 105 110	28	6,4										
5040	70 75	20	4,9	125	101	177,80	164	265	241		3 Schrauben	$\frac{7}{8} \cdot 2 \frac{5}{16} \cdot 14$
	80 85	22	5,4									
	90 95	25	5,4									
	100 105 110	28	6,4									
	115 120 125	32	7,4									
5050	70 75	20	4,9	125	127	177,80	160	265	241	3 Schrauben		$\frac{7}{8} \cdot 2 \frac{5}{16} \cdot 14$
	80 85	22	5,4									
	90 95	25	5,4									
	100 105 110	28	6,4									
	115 120 125	32	7,4									
6050	95	25	5,4	150	127	235,00	217	432	350			3 Schrauben
	100 105 110	28	6,4									
	115 120 125 130	32	7,4									
	135 140 145 150	36	8,4									

Kräfte

Type	Buchsenbohrung (mm)	Anzug (Nm)		Momente		Klemmkraft (N)
				ohne Paßfeder (Nm)	mit Paßfeder (Nm)	
1008	12	6 (5) 1/4" sw 3	2 Gewindestifte	22	136	3.990
	19			37		4.940
	24			58		5.490
1108	19			40	147	4.630
	24			62		5.220
	28			71		5.720
1210 1215	16			82	407	8.840
	19			105		9.800
	24			140		10.900
	32			180		12.300
1310	14	20 (16) 3/8" sw 5		59	435	7.800
	25			120		10.900
	35		210	12.500		
1610	19		98	486	8.500	
	24		135		9.670	
	38		240		11.900	
	42		265		12.700	
2012	24	30 (27) 7/16" sw 5	165	808	11.500	
	38		310		14.400	
	50		420		16.700	
2517 2525	38	49 (40) 1/2" sw 6	380	1.311	17.000	
	48		510		19.200	
	60		690		22.300	
3020 3030	38	90 (75) 5/8" sw 8	480	2.712	23.900	
	48		600		26.100	
	60		900		31.500	
	75		1.300		34.500	
3525 3535	42	115 (100) 1/2" sw 10	700	5.062	41.000	
	60		1.450		49.800	
	90		2.300		59.000	
4030 4040	48	170 (150) 5/8" sw 12	1.250	8.735	68.000	
	75		2.200		77.200	
	100		3.460		89.400	
4535 4545	55	190 (160) 3/4 sw 14	1.840	12.430	79.600	
	75		3.000		93.000	
	100		4.500		107.700	
5040 5050	75	270 (230) 7/8" sw 14	3.250	14.238	91.800	
	100		4.800		106.600	
	125		5.900		119.500	
			3 Inbusschrauben			