

WALTHER FLENDER CLAMPING SETS - MLC 3000

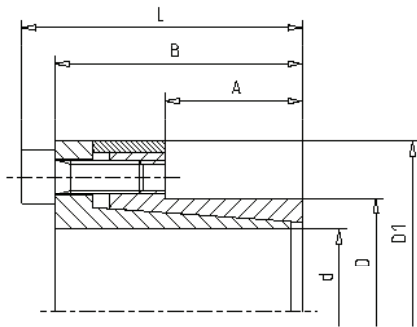

Characteristics

Material*	Steel C45
Self-centring	yes
Taper angle	self-locking
Loosening	Forcing screws

*Further materials and surface treatments are available on request

Available sizes & Technical data

Size			Dimensions				Screws		Torque	Axial forces	Surface pressure
d x D (mm)			D ₁ (mm)	A (mm)	B (mm)	L (mm)	M	M _S (Nm)	M _t (Nm)	F _{ax} (kN)	p _N (N/mm ²)
6	x	14	25	10	21,5	24,5	M 3	2,6	11	3,8	68
8	x	15	27	11,5	25	29	M 4	5,6	26	6,5	98
9	x	16	28	14	26	30	M 4	5,6	37	8	98
10	x	16	29	14	26	30	M 4	5,6	42	8	98
11	x	18	32	13,5	26	30	M 4	5,6	50	9	100
12	x	18	32	13,5	26	30	M 4	5,6	55	9	100
14	x	23	38	14	26	30	M 4	5,6	100	14	120
15	x	24	44	16	36	42	M 6	15	145	19	130
16	x	24	44	16	36	42	M 6	15	155	19	130
17	x	25	45	16	36	42	M 6	15	162	19	125
17	x	26	47	18	38	44	M 6	17	180	23	122
18	x	26	47	18	38	44	M 6	17	200	23	120
19	x	27	48	18	38	44	M 6	17	210	23	120
20	x	28	49	18	38	44	M 6	17	220	23	120
22	x	32	54	25	45	51	M 6	17	250	23	70
24	x	34	56	25	45	51	M 6	17	270	23	70
25	x	34	56	25	45	51	M 6	17	280	23	70
28	x	39	61	25	45	51	M 6	17	480	34	90
30	x	41	62	25	45	51	M 6	17	510	34	84
32	x	43	65	25	45	51	M 6	17	730	46	115
35	x	47	69	30	50	56	M 6	17	800	46	81
38	x	50	72	30	50	56	M 6	17	860	46	76
40	x	53	75	30	50	56	M 6	17	900	46	72
42	x	55	78	32	57	65	M 8	41	1.800	84	125
45	x	59	85	40	65	73	M 8	41	1.900	84	89
48	x	62	87	45	70	78	M 8	41	2.000	84	75
50	x	65	92	45	70	78	M 8	41	2.600	105	90
55	x	71	98	50	75	83	M 8	41	2.900	105	70
60	x	77	104	50	75	83	M 8	41	3.100	105	70
65	x	84	111	50	75	83	M 8	41	3.400	105	60
70	x	90	119	60	91	101	M 10	83	5.800	170	80
75	x	95	126	60	91	101	M 10	83	6.200	170	70
80	x	100	131	65	96	106	M 10	83	8.000	200	80
85	x	106	137	65	96	106	M 10	83	8.500	200	70
90	x	112	143	65	96	106	M 10	83	11.200	250	90
95	x	120	153	65	96	106	M 10	83	11.800	250	80
100	x	125	162	65	102	114	M 12	145	14.600	300	95
110	x	140	180	90	128	140	M 12	145	16.000	300	61
120	x	155	198	90	128	140	M 12	145	17.400	300	55

Recommended shaft/hub fitting tolerances h8/H8