

WALTHER FLENDER CLAMPING SETS - MLC 1000

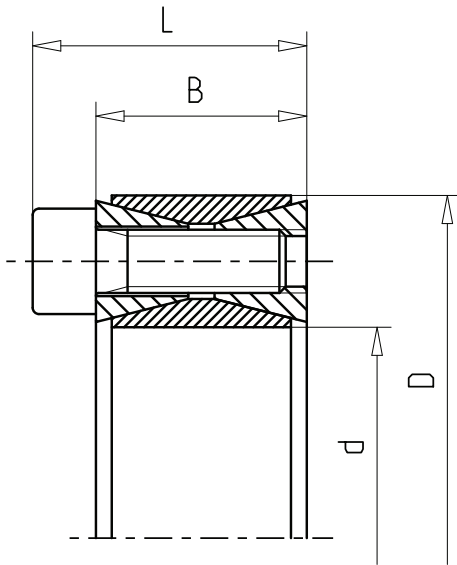

Characteristics

Material*	Steel C45
Self-centring	no
Taper angle	not self-locking
Loosening	automatic

*Further materials and surface treatments are available on request

Available sizes & Technical data

Size		Dimensions		Screws		Torque	Axial forces	Surface pressure
d x D (mm)		B (mm)	L (mm)	M	M _s (Nm)	M _t (Nm)	F _{ax} (kN)	p _N (N/mm ²)
17	x 47	20	26	M 6	16	260	31	104
18	x 47	20	26	M 6	16	280	31	104
19	x 47	20	26	M 6	16	290	31	104
20	x 47	20	26	M 6	16	310	31	104
22	x 47	20	26	M 6	16	340	31	104
24	x 50	20	26	M 6	16	370	31	98
25	x 50	20	26	M 6	16	390	31	98
28	x 55	20	26	M 6	16	650	46	133
30	x 55	20	26	M 6	16	700	47	133
32	x 60	20	26	M 6	16	750	47	122
35	x 60	20	26	M 6	16	820	47	122
38	x 65	20	26	M 6	16	1.100	58	141
40	x 65	20	26	M 6	16	1.170	59	141
42	x 75	24	32	M 8	40	1.670	80	145
45	x 75	24	32	M 8	40	1.790	80	145
48	x 80	24	32	M 8	40	1.900	79	136
50	x 80	24	32	M 8	40	1.990	80	136
55	x 85	24	32	M 8	40	2.740	100	160
60	x 90	24	32	M 8	40	2.990	100	151
65	x 95	24	32	M 8	40	3.240	100	143
70	x 110	28	38	M 10	78	5.550	159	160
75	x 115	28	38	M 10	78	5.950	159	153
80	x 120	28	38	M 10	78	6.350	159	146
85	x 125	28	38	M 10	78	6.740	159	140
90	x 130	28	38	M 10	78	7.140	159	135
95	x 135	28	38	M 10	78	9.000	189	156
100	x 145	32	44	M 12	135	11.600	232	164
110	x 155	32	44	M 12	135	12.750	232	153
120	x 165	32	44	M 12	135	14.800	247	153
130	x 180	38	50	M 12	135	20.150	310	134
140	x 190	38	50	M 12	135	23.850	341	140
150	x 200	38	50	M 12	135	27.850	371	145
160	x 210	38	50	M 12	135	32.200	403	150
170	x 225	44	58	M 14	215	40.300	475	148
180	x 235	44	58	M 14	215	46.600	518	154
190	x 250	52	66	M 14	215	57.300	604	139
200	x 260	52	66	M 14	215	71.000	711	158
220	x 285	56	72	M 16	335	93.200	849	158
240	x 305	56	72	M 16	335	117.300	979	170
260	x 325	56	72	M 16	335	144.000	1.110	181
280	x 355	66	84	M 18	465	177.700	1.271	158
300	x 375	66	84	M 18	465	214.100	1.430	168
320	x 405	78	98	M 20	660	295.800	1.852	168

Recommended shaft/hub fitting tolerances h9/H9