

WALTHER FLENDER CLAMPING SETS - MLC 6000

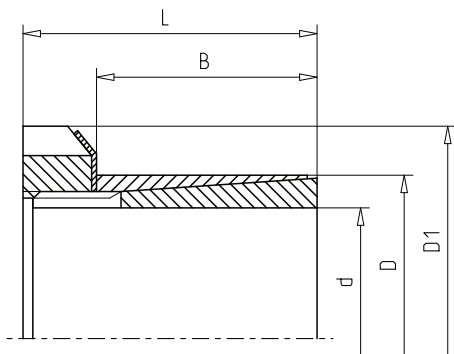

Characteristics

Material*	Steel C45
Self-centring	no
Taper angle	self-locking
Loosening	slight shocks

*Further materials and surface treatments are available on request

Available sizes & Technical data

Size		Dimensions			Tightening torque	Torque	Axial forces	Surface pressure
d x D (mm)		D ₁ (mm)	B (mm)	L (mm)	M _S (Nm)	M _T (Nm)	F _{AX} (kN)	P _N (N/mm ²)
14	x 25	32	17	29	90	90	15	80
15	x 25	32	17	29	90	100	15	80
16	x 25	32	17	29	70	80	12	60
17	x 25	38	18	31	90	113	12	70
18	x 30	38	18	31	190	200	25	110
19	x 30	38	18	31	150	170	20	90
20	x 30	38	18	31	110	130	15	60
22	x 35	45	22	35	130	180	18	60
24	x 35	45	22	35	230	270	26	80
25	x 35	45	22	35	170	200	20	60
28	x 40	52	22	35	390	460	40	110
30	x 40	52	22	35	240	300	24	70
32	x 45	58	27	42	320	420	31	70
35	x 45	58	28	42	320	460	31	60
40	x 50	65	28	44	440	640	37	70
45	x 55	70	28	45	550	760	40	60
50	x 60	75	28	46	660	930	44	60
55	x 65	80	28	47	800	1.130	47	60
60	x 70	85	28	52	1.050	1.500	59	70

Recommended shaft/hub fitting tolerances h8/H8