

## WALTHER FLENDER SPANNSÄTZE - MLC 5006

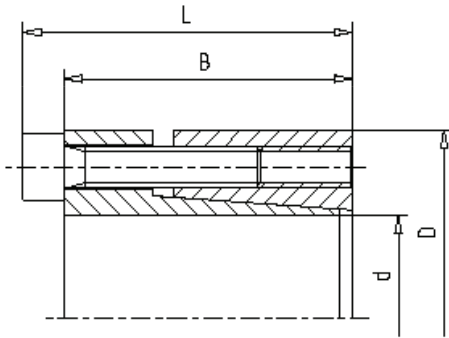

### Eigenschaften

Werkstoff*	Stahl C45
Selbstzentrierung	ja
Kegelwinkel	selbsthemmend
Entspannen	Abdrückschrauben

\*Weitere Werkstoffe sowie Oberflächenbehandlungen auf Anfrage

### Verfügbare Größen & Technische Daten

Größe		Maße		Schrauben		Drehmoment	Axialkraft	Flächenpressung an der Nabe	
d x D (mm)		B (mm)	L (mm)	M	M <sub>S</sub> (Nm)	M <sub>t</sub> (Nm)	F <sub>AX</sub> (kN)	p <sub>N</sub> (N/mm <sup>2</sup> )	
18	x	47	28	34	M 6	14	370	41	140
19	x	47	28	34	M 6	14	390	41	140
20	x	47	28	34	M 6	14	410	41	140
22	x	47	28	34	M 6	14	450	41	140
24	x	50	28	34	M 6	14	490	41	130
25	x	50	28	34	M 6	14	510	41	130
28	x	55	28	34	M 6	14	570	41	120
30	x	55	28	34	M 6	14	610	41	120
32	x	60	28	34	M 6	14	880	55	145
35	x	60	28	34	M 6	14	960	55	145
38	x	65	28	34	M 6	14	1.000	55	135
40	x	65	28	34	M 6	14	1.100	55	135
42	x	75	33	41	M 8	35	2.200	105	190
45	x	75	33	41	M 8	35	2.400	105	190
48	x	80	33,5	41	M 8	35	2.500	105	175
50	x	80	33,5	41	M 8	35	2.600	105	175
55	x	85	33,5	41	M 8	35	2.900	105	165
60	x	90	33,5	41	M 8	35	3.100	105	155
65	x	95	33,5	41	M 8	35	3.400	105	150
70	x	110	40	50	M 10	70	6.000	170	175
75	x	115	40	50	M 10	70	6.400	170	170
80	x	120	40	50	M 10	70	6.800	170	160
85	x	125	40	50	M 10	70	9.000	210	190
90	x	130	40	50	M 10	70	9.600	210	185
95	x	135	40	50	M 10	70	10.200	210	185
100	x	145	44	56	M 12	115	12.000	235	170
110	x	155	44	56	M 12	115	13.000	260	160
120	x	165	44	56	M 12	115	16.000	270	165
130	x	180	52	64	M 12	115	23.000	350	155
140	x	190	54	68	M 14	185	25.000	360	150
150	x	200	54	68	M 14	185	30.000	400	155
160	x	210	54	68	M 14	185	38.800	480	170

Empfohlene Einbautoleranzen Welle/Nabe h8/H8